

WERKZEUGBOX

Toolbox | Boîte à outils | Caja de herramientas | Cassetta degli attrezzi

DE Die Farben der Abbildungen dienen nur der Veranschaulichung.

EN The colors are for illustrating purposes only.

FR Les couleurs utilisées sont à titre indicatif seulement.

Artikel.-Nr: 41601-000

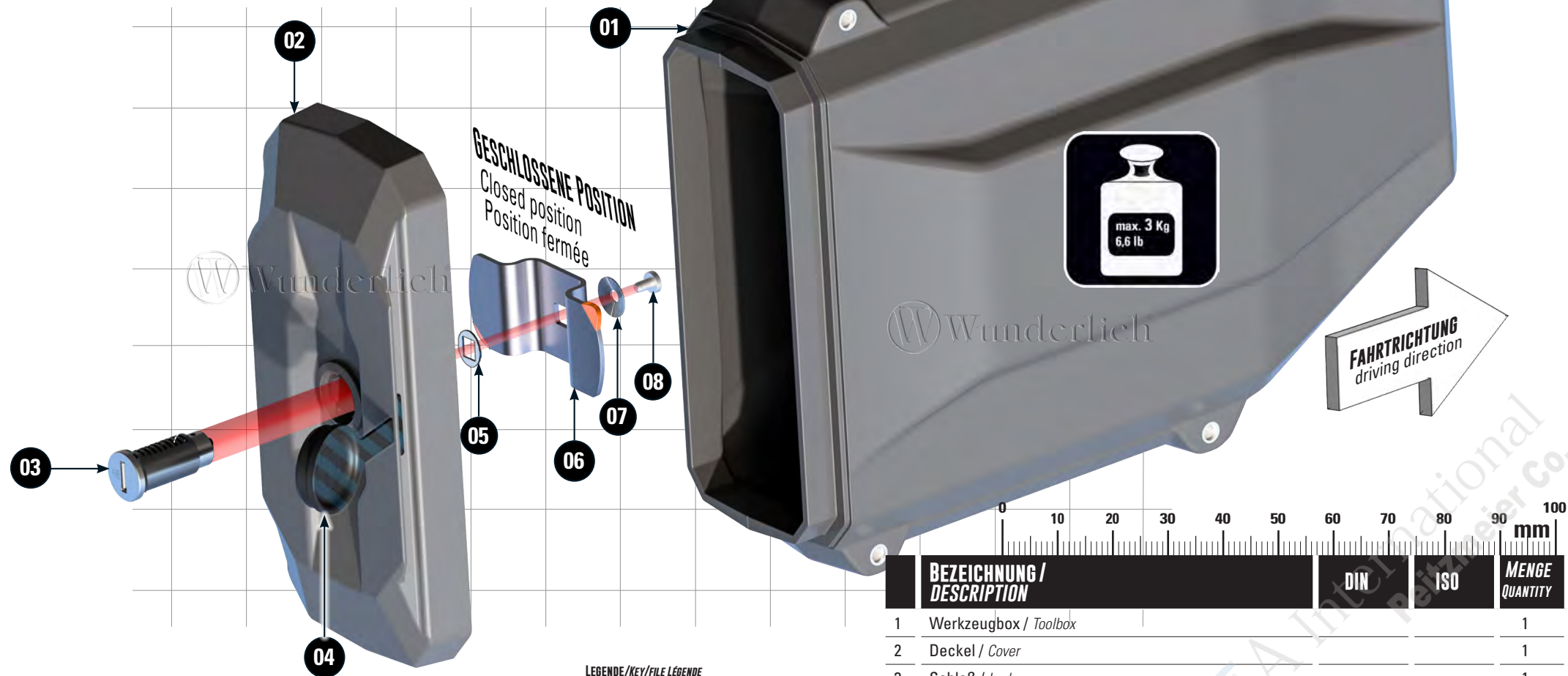

LEGENDE/KEY/FILE LÉGENDE

Anbau Tip
Fitting tip
Astuce de montage

Achtung
Attention
Attention

Vergrößerung
Magnification
Grossissement

Montagepaste
Fitting lubricant
Lubrifiant de montage

Schraube
Screw
Vis

Schraubensicherung
Thread locking fluid
Freinfilets

M Nm
Drehmoment
Torque

BEZEICHNUNG / DESCRIPTION		DIN	ISO	MENGE QUANTITY
1	Werkzeugbox / Toolbox			1
2	Deckel / Cover			1
3	Schloß / Lock			1
4	Schutzkappe / Protective cap			1
5	Passscheibe / Shim $\text{D}\varnothing 13,5 - \text{h} 0,5 \text{ mm}$			1
6	Schließblech / Locking plate			1
7	Spannscheibe / Clamping washer			1
8	Linsenflanschschraube / Lens head screw $\text{M}4 \times 6$ Torx Ersatzschraube / spare screw	7381SA2	7381SA2	1



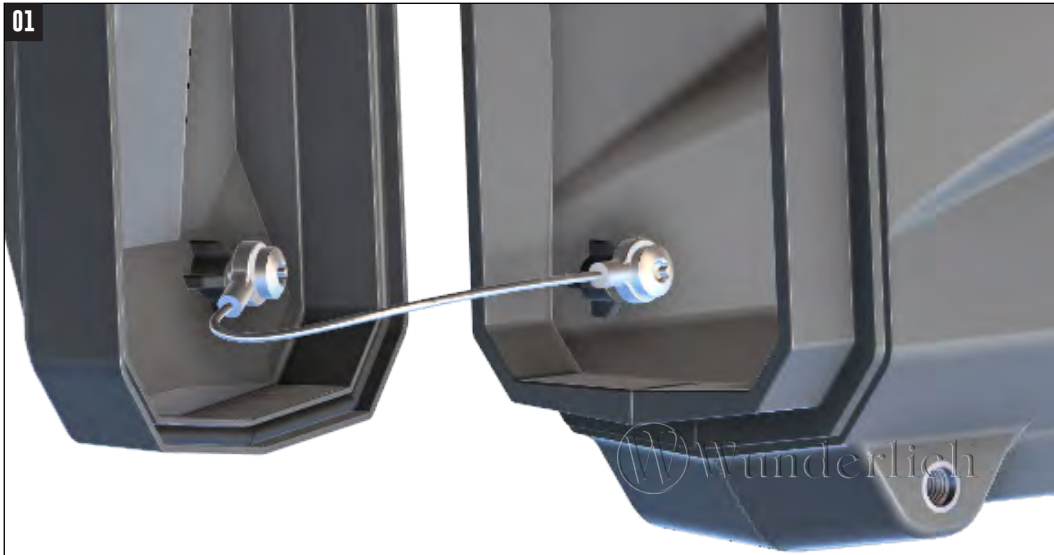

DE BEI VERRIEGELTER BOX, HAT SICH DIE DICHTUNG NACH 1-2 TAGEN OPTIMAL ANGEPAST. DIE PASSSCHEIBE WIRD ZUR FEINEINSTELLUNG GENUTZT, DURCH ENTFERNEN ERHÖHT SICH DIE ZUGKRAFT DES SCHLIEßBLECHES.

EN With the box locked, the seal will have adjusted itself optimally after 1-2 days. The shim is used for fine adjustment, removing it increases the tension of the striker plate.

FR Avec la boîte verrouillée, le joint se sera ajusté de manière optimale après 1 à 2 jours. La cale est utilisée pour le réglage fin, son retrait augmente la tension de la gâche.







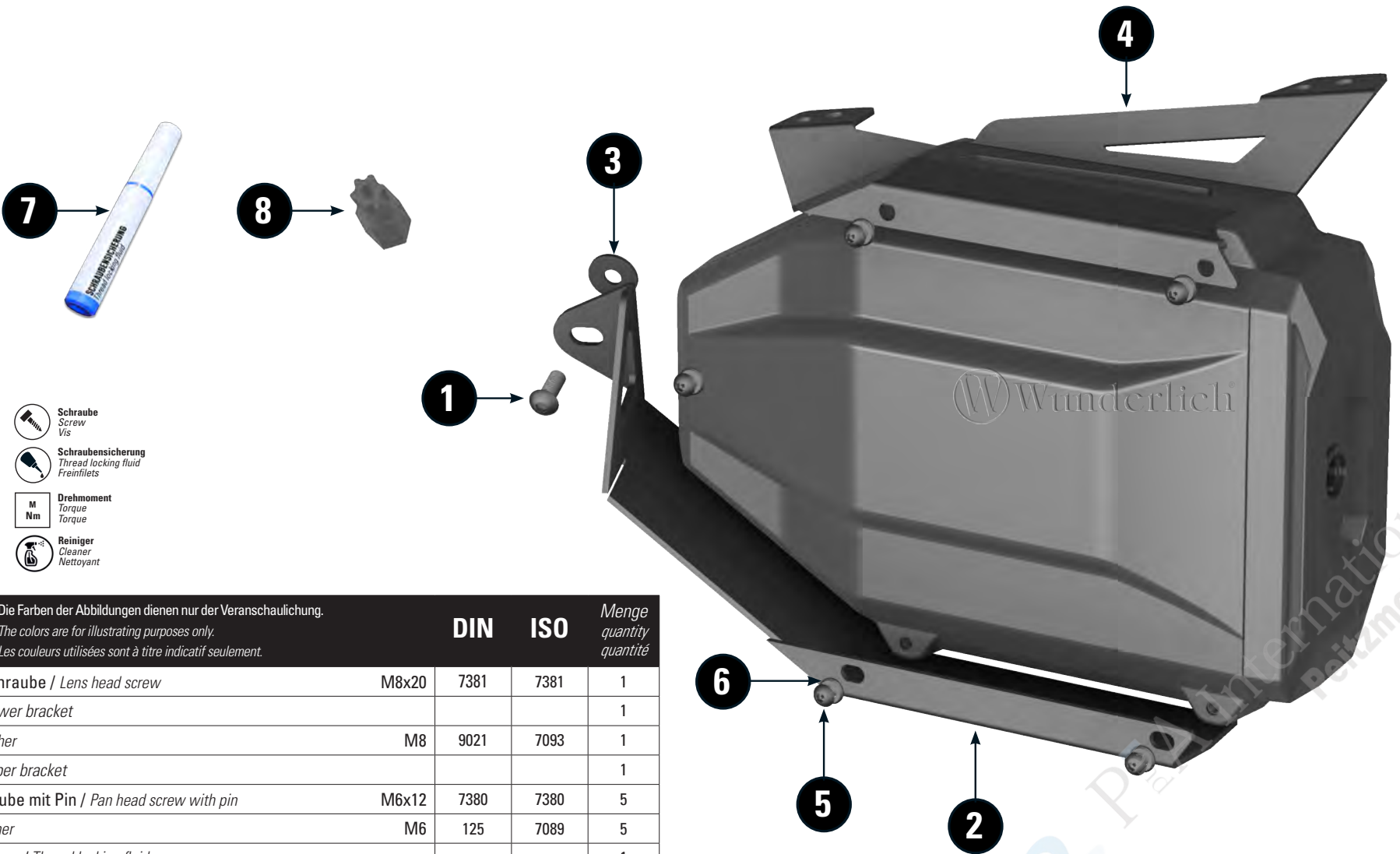

WERKZEUGBOX R 1300 GS ADV – EXTREME-TRÄGER, OHNE KOFFERAUFNAHMEN

Tool box R 1300 GS ADV – EXTREME rack, without case mounts | Boîte à outils R 1300 GS ADV – Support EXTREME, sans fixations pour valises | Cassetta portattrezzi R 1300 GS ADV – Telaio EXTREME, senza supporti per valigie | Caja de herramientas R 1300 GS ADV – Soporte EXTREME, sin soportes para maletas

Art.-Nr: 13246-X02



LEGENDE/KEY/FILE LÉGENDE

-  **Anbau Tipp**
Fitting tip
Astuce de montage
-  **Achtung**
Attention
Attention
-  **Vergößerung**
Magnification
Grossissement
-  **Montagepaste**
Fitting lubricant
Lubrifiant de montage
-  **Schraube**
Screw
Vis
-  **Schraubensicherung**
Thread locking fluid
Freiniflets
-  **Drehmoment**
Torque
Torque
-  **Reiniger**
Cleaner
Nettoyant

#	Bauteil component composant	DE Die Farben der Abbildungen dienen nur der Veranschaulichung. EN The colors are for illustrating purposes only. FR Les couleurs utilisées sont à titre indicatif seulement.	DIN	ISO	Menge quantity quantité
1	Linsenflanschschraube / Lens head screw		M8x20	7381 7381	1
2	Halter unten / Lower bracket				1
3	U-Scheibe / Washer		M8	9021 7093	1
4	Halter oben / Upper bracket				1
5	Linsenkopfschraube mit Pin / Pan head screw with pin		M6x12	7380 7380	5
6	U-Scheibe / Washer		M6	125 7089	5
7	Schraubensicherung / Thread locking fluid				1
8	Bit 1/4" Torx 30 mit Bohrung / 1/4" Torx T30 security bit				1



1

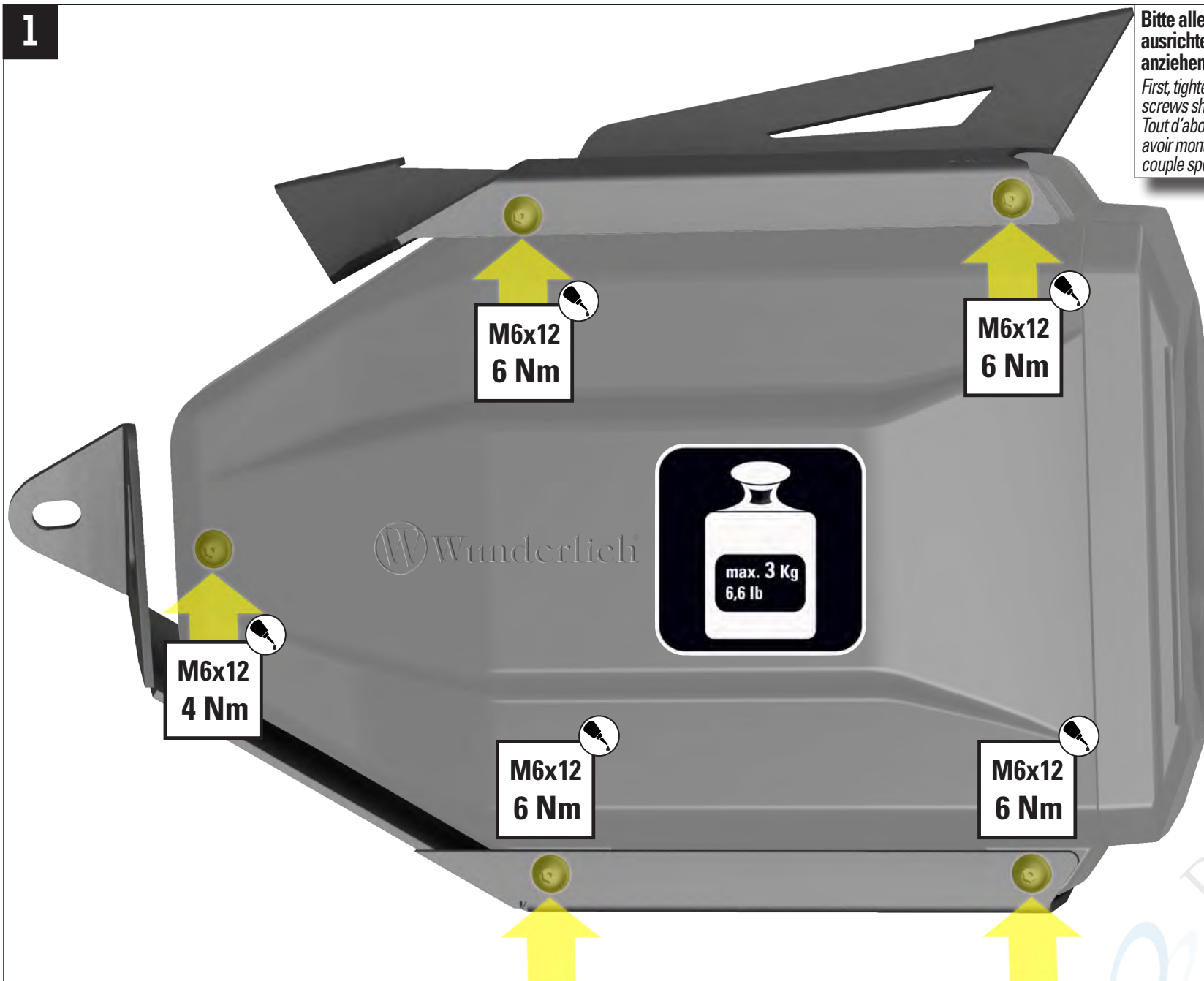

Bitte alle Anbauteile lose am Fahrzeug vormontieren und ausrichten. Erst danach die Schrauben nach Vorgabe anziehen.

First, tighten all screws only loosely. After mounting all parts, the screws should be tightened to the torque specified.

Tout d'abord, ne serrez pas toutes les vis sans les serrer. Après avoir monté toutes les pièces, les vis doivent être serrées au couple spécifié.

2



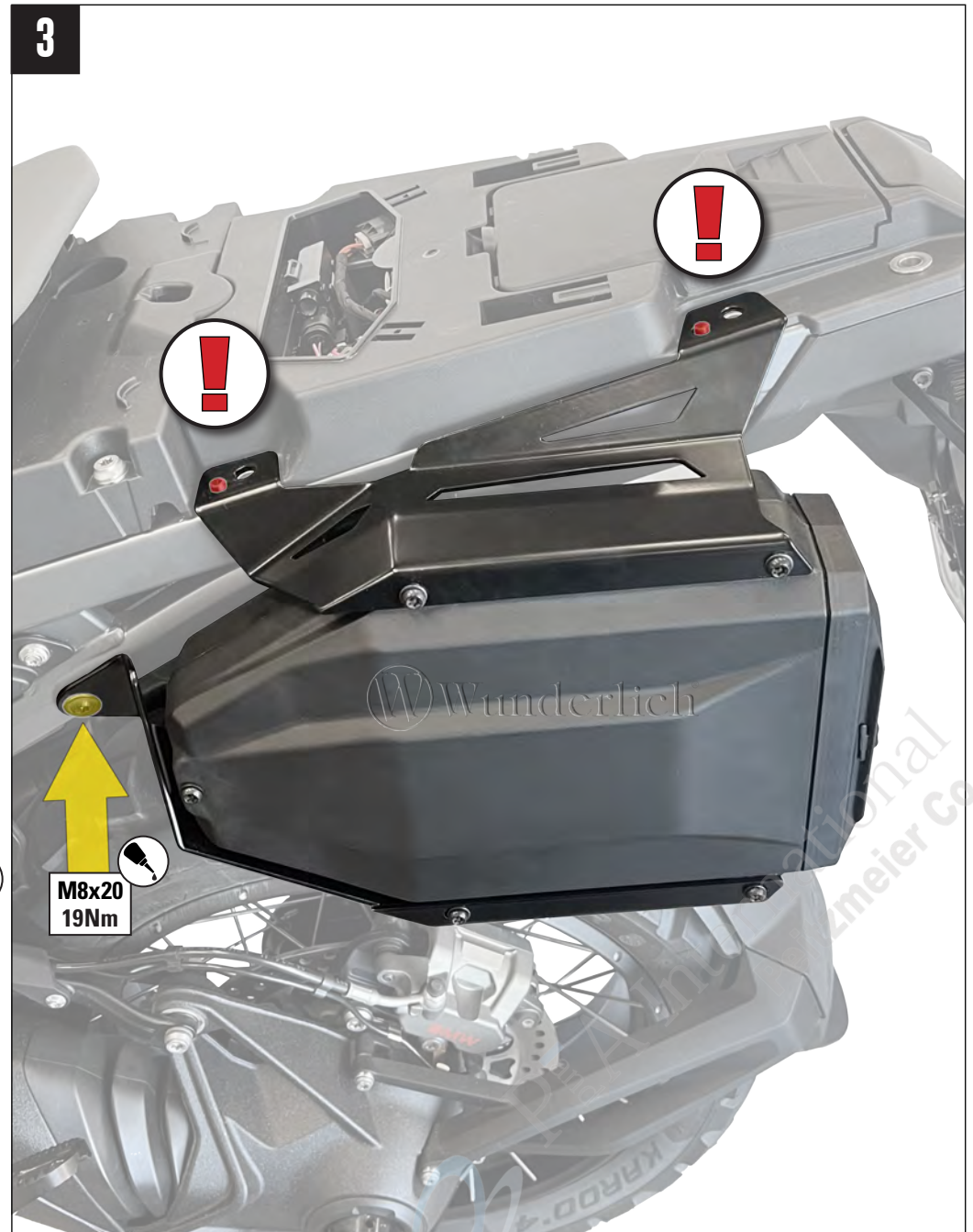
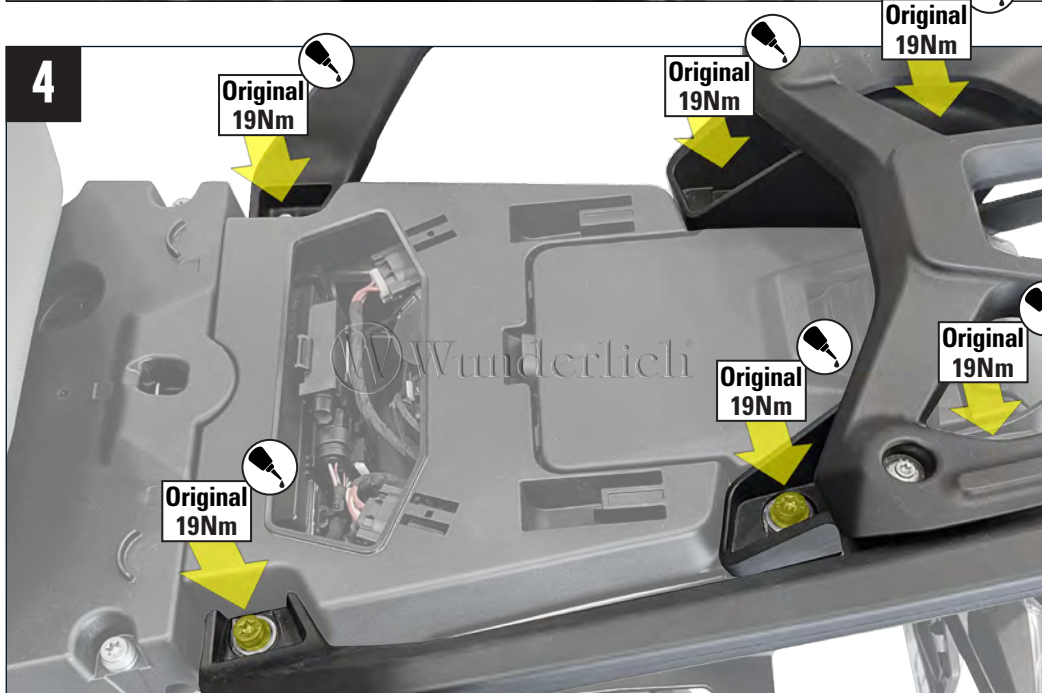

MONTAGE IN KOMBINATION MIT KOFFERTRÄGER EXTREME

Installation in combination with EXTREME case carrier | Montage en combinaison avec le support de valise EXTREME | Montaggio in combinazione con il portavaligie EXTREME | Montaje en combinación con el portamaletas EXTREME

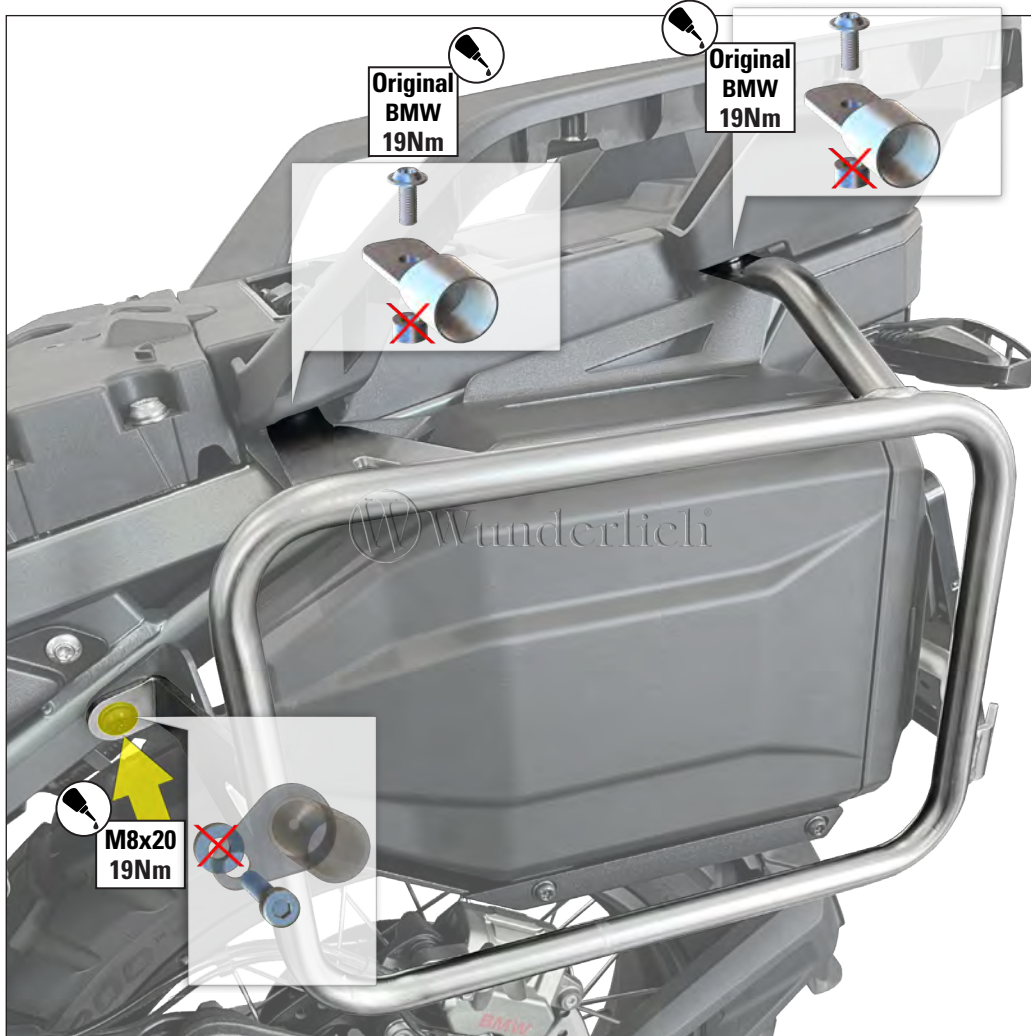

Die Hülsen des EXTREME-Trägers entfallen. Stattdessen wird an dieser Stelle die Werkzeugbox befestigt. Montieren Sie bitte zuerst die Werkzeugbox, danach den EXTREME-Kofferträger.

The spacers of the EXTREME rack are omitted. Instead, the tool box is mounted at this position.
Please install the tool box first, then the EXTREME case carrier. Les entretoises du support EXTREME ne sont pas utilisées.
À leur place, la boîte à outils est installée. Veuillez d'abord monter la boîte à outils, puis le support de valise EXTREME.

