

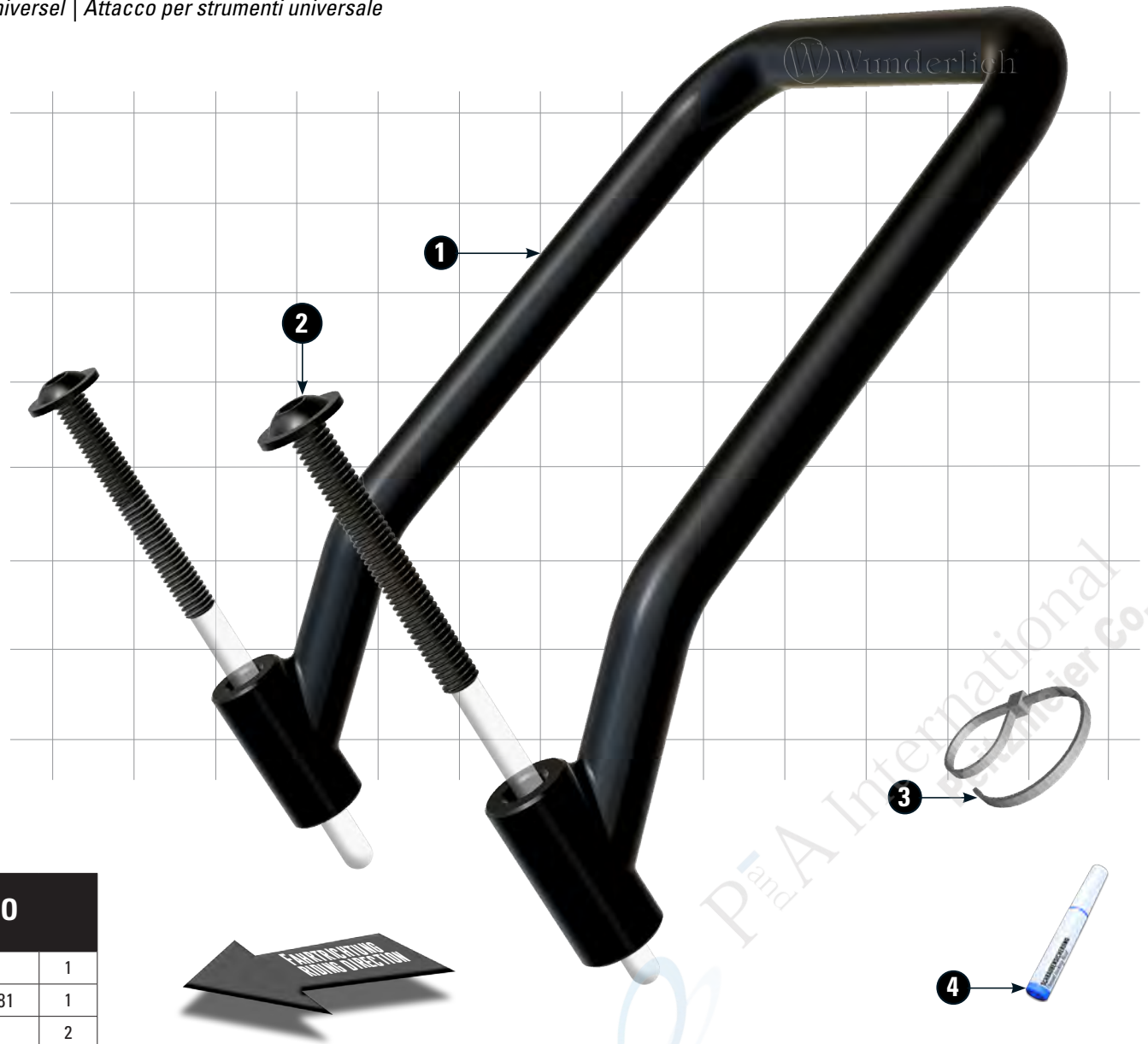



# GERÄTETRÄGER UNIVERSAL





Universal device carrier | Portadispositivos universal | Support-appareil universel | Attacco per strumenti universale

Art.-Nr: 13176-002 / 14152-002



## LEGENDE/KEY/FILE LÉGENDE

-  **Anbau Tipp**  
Fitting tip  
Astuce de montage
-  **Achtung**  
Attention  
Attention
-  **Vergrößerung**  
Magnification  
Grossissement
-  **Montagepaste**  
Fitting lubricant  
Lubrifiant de montage

-  **Schraube**  
Screw  
Vis
-  **Schraubensicherung**  
Thread locking fluid  
Freinfilets
-  **Drehmoment**  
Torque  
Torque
-  **Reiniger**  
Cleaner  
Nettoyant

#	Bauteil component composant	DE Die Farben der Abbildungen dienen nur der Veranschaulichung. EN The colors are for illustrating purposes only. FR Les couleurs utilisées sont à titre indicatif seulement.	DIN	ISO	
1	Geräteträger / Device carrier				1
2	VA Linsenflanschschraube / VA Lens head screw	M6x45 (Torx)	7381	7381	1
3	Kabelbinder / Cable tie				2
4	Schraubensicherung / Thread locking fluid				1



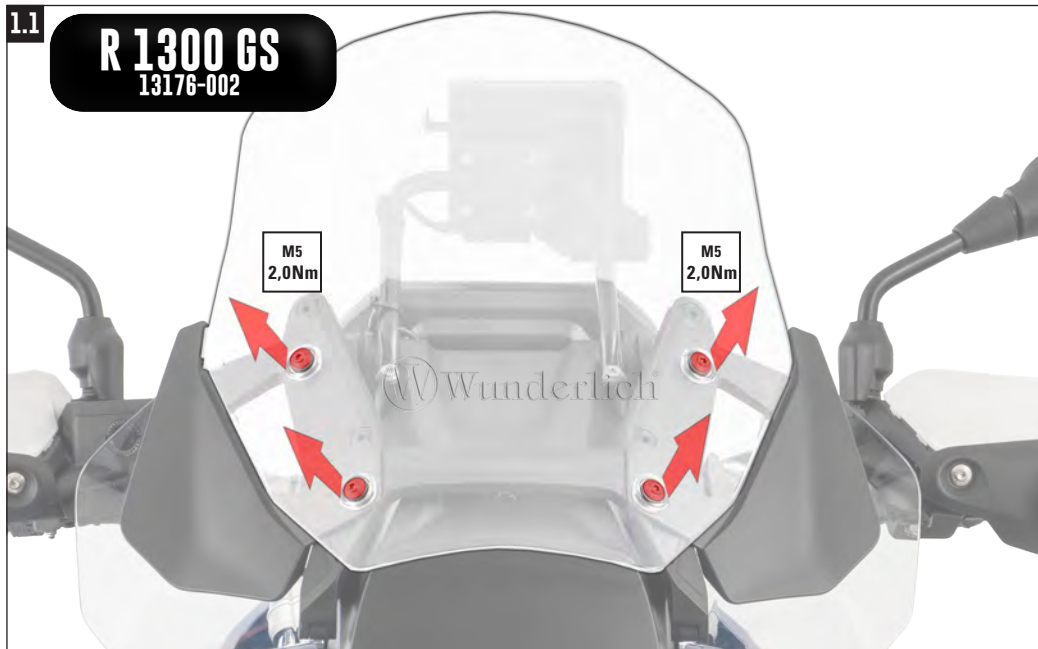

2.1

**R 1300 RT**  
 14152-002

2.2

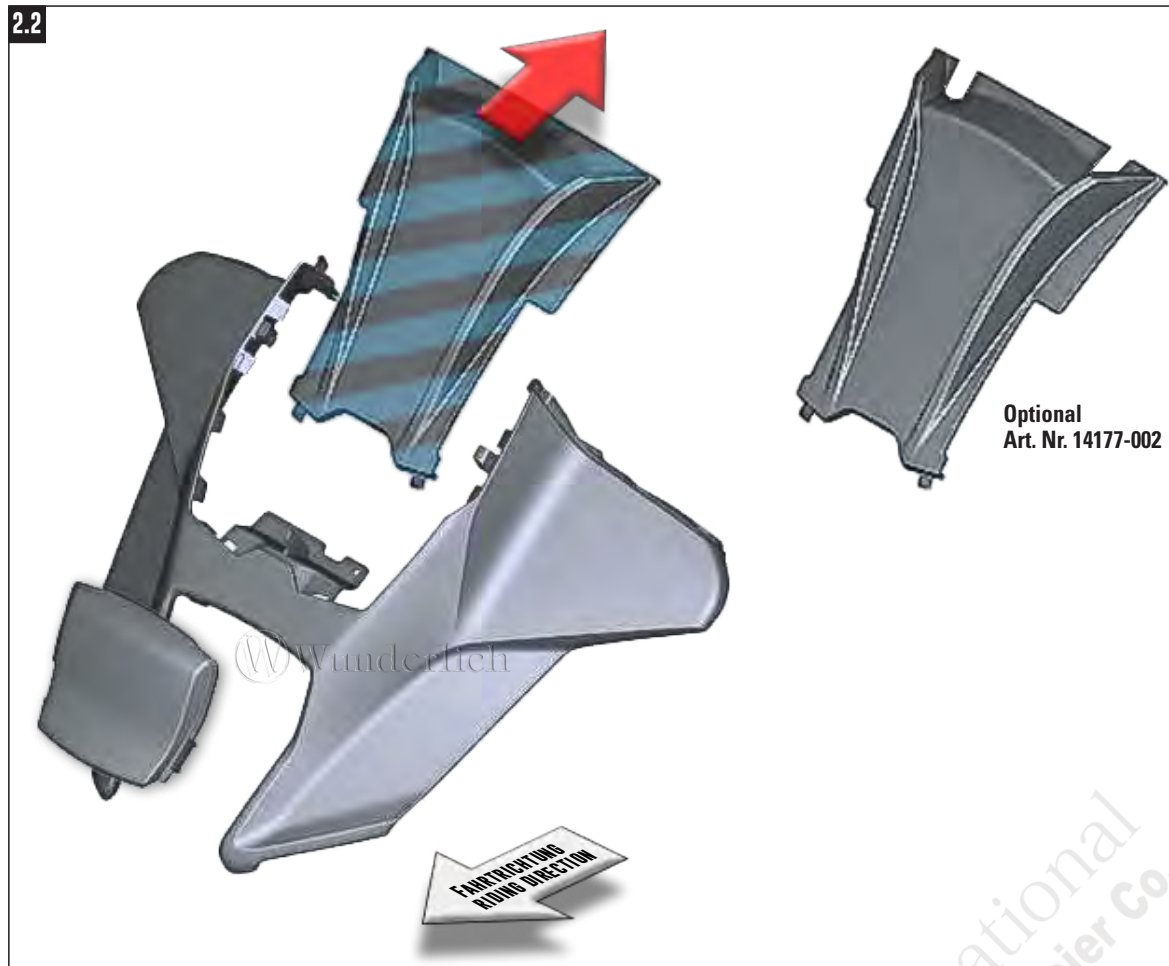

**Ist das Windschild demontiert, kann die Abdeckung der Windschildverstellung (hier schraffiert dargestellt) entnommen werden. Diese ist oben geclipst. In Kombination mit dem Universal Träger muss die Abdeckung noch ausgeklinkt werden (siehe Seite 4). Die fertig ausgeklinkte Abdeckung, Artikelnummer 14177-002, ist in unserem Shop erhältlich. In diesem Fall weiter auf Seite 5.**

*Once the windshield has been removed, the cover for the windshield adjustment (shaded area shown here) can be removed. Remove the cover from the upper clip fasteners. This must still be unclipped in combination with the universal bracket (see page 4). The finished cover, item no. 14177-002, is available in our shop. Continue to page 5.*

*Une fois le pare-brise retiré, le cache du réglage du pare-brise (ombragé ici) peut être retiré. Retirez le couvercle des attaches supérieures. Celui-ci doit encore être décroché en même temps que le support universel (voir page 4). La housse finie, référence 14177-002, est disponible dans notre boutique. Continuez à la page 5.*

2.3

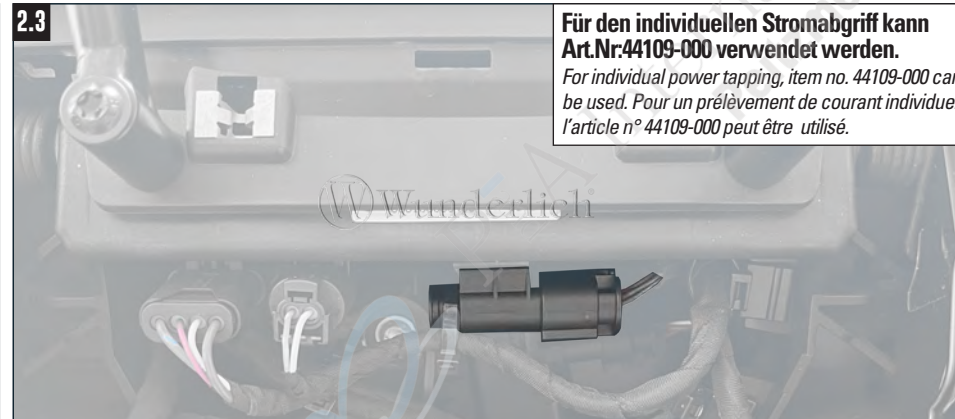

**Für den individuellen Stromabgriff kann Art.Nr.44109-000 verwendet werden.**

*For individual power tapping, item no. 44109-000 can be used. Pour un prélèvement de courant individuel, l'article n° 44109-000 peut être utilisé.*

# R 1300 RT

Wunderlich



**Mit geeignetem Werkzeug ausklinken.**  
*Notch out using a suitable tool.*  
*Entaillez à l'aide d'un outil approprié.*

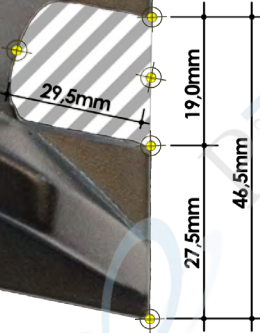



# ACCESSORIES



Art.-Nr: **21176-102**



Art.-Nr: **39001-625/641**



Art.-Nr: **45151-008**



Art.-Nr: **45151-022**